

客户图
Customer drawings

CN40-CMMM-01

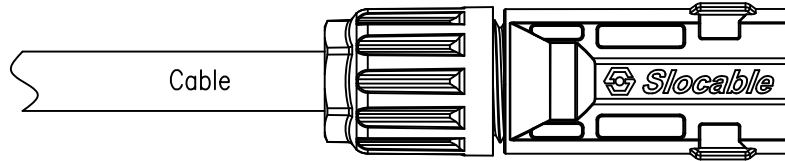

CN40-CFPM-01

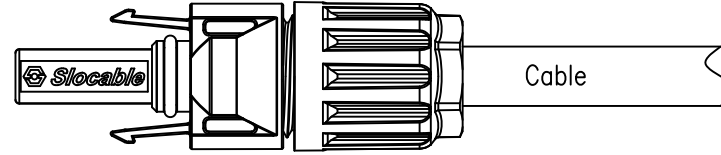

Insulation material	PPO
Rated current	50A(2.5mm ²), (4.0mm ²), (6.0mm ²)
Rated voltage	1000V(TUV) 600V(UL) 1500V(TUV)
Test voltage	6kV(50Hz,1min)
Contact resistance	<1mΩ
Contact material	Copper, Tin plated
Degree of protection	IP2X/IP68
Safety class	II
Flame class	UL94-V0
Insertion force	Max. 50N
Withdrawal force	Min. 50N
Ambient temperature range	-40°C...+90°C(IEC/CEI)
Suitable cable cross sections	2.5/4.0/6.0mm ² AWG14/12/10
Pin dimensions	∅4.0mm

订货料号 Order No.	零部件料号 Part P/N		适用电缆规格(Cable Spec)	
	连接器 Connector	端子 Terminal	导体截面 (mm ²) Conductor Size	电缆外径(∅D mm) Cable OD
CN40-CM-01	公接头 CN40-CMMM-H	公端子 CN40-CM-MT01	AWG14(2.5mm ²) AWG12(4.0mm ²)	∅4.5~∅8.5
	母接头 CN40-CFPM-H	母端子 CN40-CM-FT01	AWG10(6.0mm ²)	

				尺寸公差	角度公差	核准	万能 2017.12.15	材质	产品 名称 C4 Cable connector		 Dongguan Slocable Photovoltaic Technology Co., Ltd.	
				X.0 ±0.25	X.0° ±1°	审核	万能 2017.12.15	表面处理				
				0.X ±0.13	0.X° ±0.5°	设计	万能 2017.12.15	角法	比例	专案 编号 P-17018		文件 编号 DWG-17018-S01
版本	修订日期	修订内容	修订人	0.0X ±0.05	0.0X° ±0.2°	绘图	万能 2017.12.15	页次	1/4	单位	mm	

客户图
Customer drawings

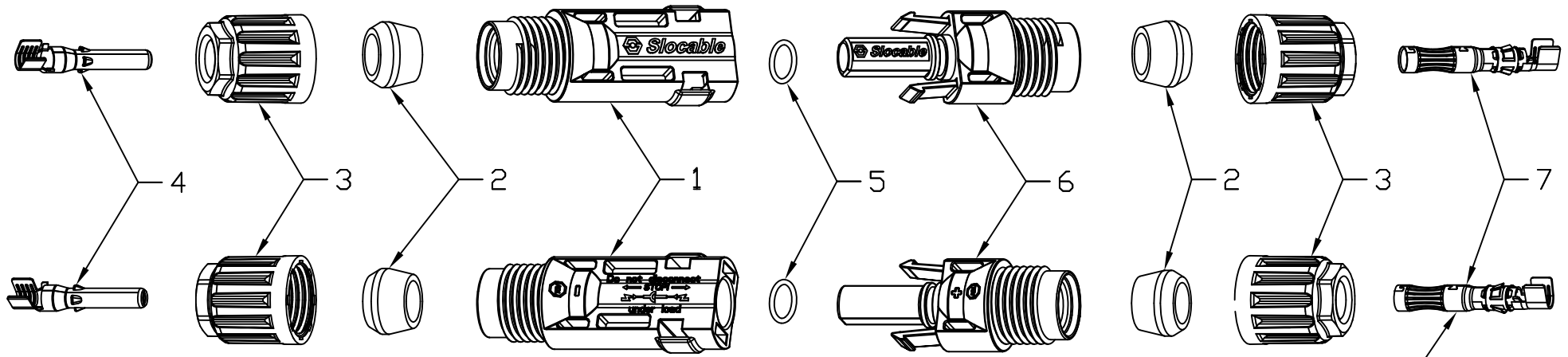

BILL OF MATERIALS

No.	零件编号 P/N	产品名称 Part Name	规格 Description	Q'TY
1	P17018-011	C4公接头主体 C4 Male Housing	PPO PX9406P-7001, SABIC, UL E207780	1
2	P17018-003	C4接头电缆防水圈 C4 Cable Seal Ring	SHIN-ETSU, CHN-9500-U, SHIN-ETSU SILICONE, UL E360537	2
3	P17018-001	M16*1.5旋帽 M16*1.5 Screw Cap	PPO PX9406P-7001, SABIC, UL E207780	2
4	P17018-110	C4公端子 C4 Male Terminal	Cu, Plating Tin	1
5	P17018-004	C4母接头密封圈 C4 Female Conn O Ring	SHIN-ETSU, CHN-9500-U, SHIN-ETSU SILICONE, UL E360537	1
6	P17018-021	C4母接头主体 C4 Female Housing	PPO PX9406P-7001, SABIC, UL E207780	1
7-1	P17018-120	C4母端子 C4 Female Terminal	Cu, Plating Tin	1
7-2	P17011-105	C4母端子定位扣 C4 Female Terminal Fixed buckle	SK7, Plating Ni	1

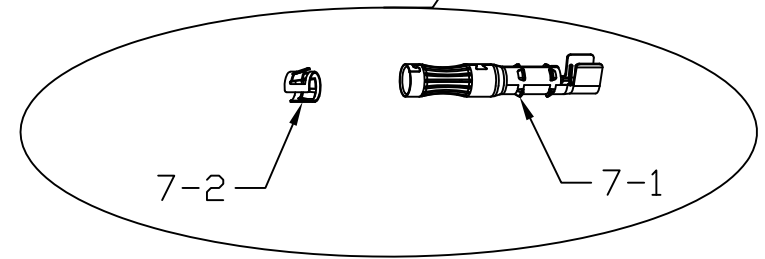

版本		修订日期	修订内容	修订人	尺寸公差	角度公差	核准	万能 2017.12.15	材质	产品名称 C4 Cable connector 产品料号 CN40-CM-01 专案编号 P-17018	Slocable Dongguan Slocable Photovoltaic Technology Co., Ltd.	
					X.0 ±0.25	X.0° ±1°	审核	万能 2017.12.15	表面处理			
					0.X ±0.13	0.X° ±0.5°	设计	万能 2017.12.15	角法			比例
					0.0X ±0.05	0.0X° ±0.2°	绘图	万能 2017.12.15	页次 2/4			单位 mm
文件编号		DWG-17018-S01										

P/N: CN40-CFPM-H

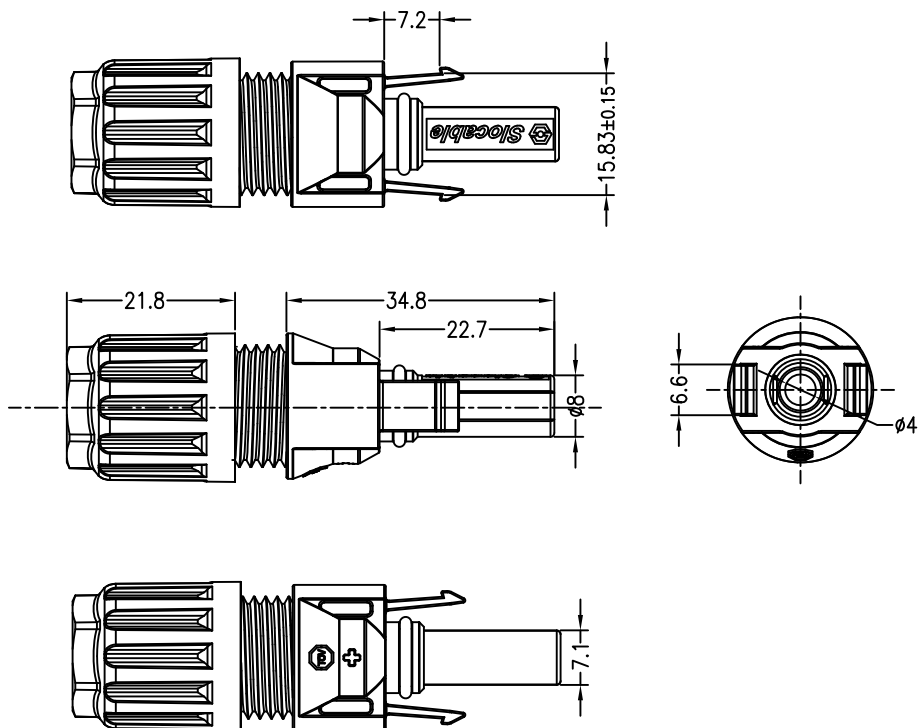

客户图
Customer drawings

订货料号 Order No.	零部件料号 Part P/N		适用电缆规格 (Cable Spec)	
	连接器 Connector	端子 Terminal	导体截面 (mm ²) Conductor Size	电缆外径 (ØD mm) Cable OD
CN40-CFPM-01	CN40-CFPM-H	CN40-CM-FT01	AWG14(2.5mm ²)	Ø4.5~Ø8.5
			AWG12(4.0mm ²)	
			AWG10(6.0mm ²)	

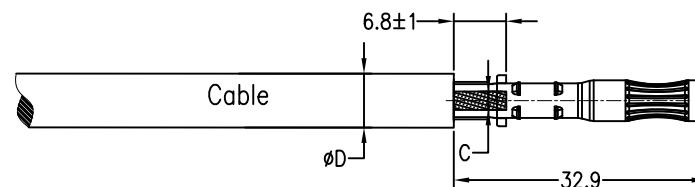

P/N: CN40-CM-FT01

[适用于2.5mm²(14AWG)、4.0mm²(12AWG)、6.0mm²(10AWG)]

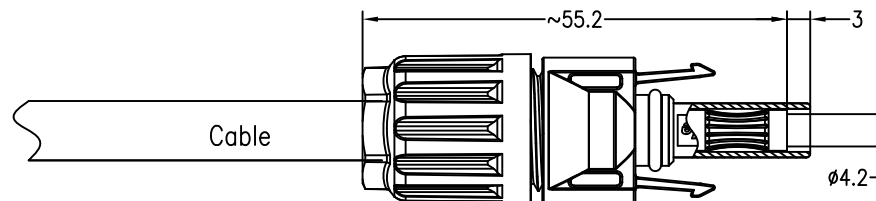
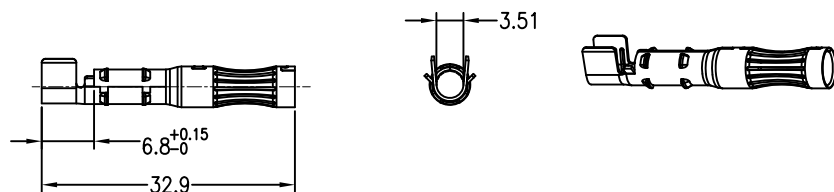

版本		修订日期	修订内容	修订人	尺寸公差	角度公差	核准	日期	材质	表面处理	角法	比例	单位	mm	产品名称	产品料号	专案编号	文件编号	图号
					X.0 ±0.25	X.0° ±1°	审核	2017.12.15							C4 Cable Connector -Female Plug	CN40-CFPM-01	P-17018	DWG-17018-S01	
					0.X ±0.13	0.X° ±0.5°	设计	2017.12.15											
					0.0X ±0.05	0.0X° ±0.2°	绘图	2017.12.15											



Dongguan Slocable Photovoltaic Technology Co., Ltd.